

EXPERIMENTAL EVALUATION OF INTERFERENCE ALIGNMENT UNDER IMPERFECT CHANNEL STATE INFORMATION

J. A. García-Naya and L. Castedo

Dept. of Electronics and Systems
University of A Coruña, 15071 A Coruña, Spain
Email: {jagarcia, luis}@udc.es

Ó. González, D. Ramírez and I. Santamaria

Dept. of Communications Engineering
University of Cantabria, 39005 Santander, Spain
Email: {oscarfg, ramirezgd, nacho}@gtas.dicom.unican.es

ABSTRACT

Interference Alignment (IA) has been revealed as one of the most attractive transmission techniques for the K -user interference channel. In this work, we employ a multiuser Multiple-Input Multiple-Output (MIMO) testbed to analyze, in realistic indoor scenarios, the impact of channel state information errors on the sum-rate performance of IA. We restrict our study to a 3-user interference network in which each user transmits a single data stream using two transmit and two receive antennas. For this MIMO interference network, only two different IA solutions exist. We also evaluate the performance gain obtained in practice by using the IA solution that maximizes the sum-rate.

1. INTRODUCTION

In wireless communications, an interference channel is obtained when various transmitter-receiver pairs operate simultaneously, sharing the same transmission medium. In this way, as shown in Fig. 1, data transmission from one transmitter to the corresponding receiver is interfered by the rest of the two transmitters in the network. Interference Alignment (IA) has been recently introduced as an attractive transmission technique for the K -user interference channel [1, 2], which is based on maximizing the interference-free space for the desired signal. In [2], it is shown that all the interference can be concentrated into half of the signal space at each receiver, whereas the remaining half is still available—free of interference—for the desired signal.

Unfortunately, most of the literature about IA is limited to theoretical analyses and computer simulations that rely only on synthetic, ideal, wireless channel models. Although the experimental evaluation of IA requires a complex set-up (e.g. three two-antenna transmitters and three two-antenna receivers for assessing the simplest 3-user interference network), it is important to evaluate the robustness and performance of IA under real-world circumstances (e.g. imperfect Channel State Information (CSI)). The insights obtained can be later used to improve current IA techniques.

To the best of our knowledge, the first experimental work on IA was presented in [3], where a technique that combines interference alignment and cancellation was implemented in a testbed made up of 20 Ettus Research LLC nodes with two antennas each. Several practical issues have been evaluated in this work, such as the impact of different modulations, frequency/time synchronization aspects, or the idea of applying the alignment at the sample level (i.e., before timing and frequency offset correction). However, this technique requires an additional wired Ethernet connection to transfer already decoded packets between access points to cancel out some streams.

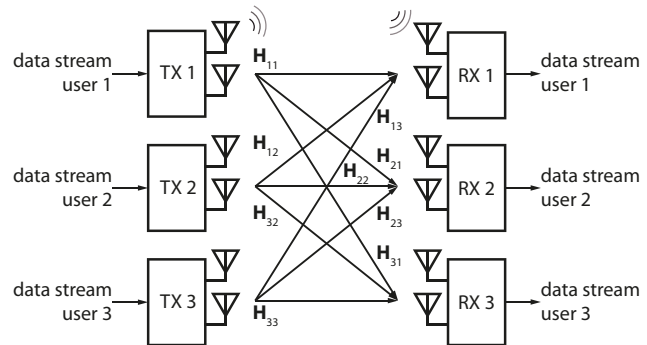

Figure 1: Scheme of the $(2 \times 2, 1)^3$ interference network.

Another experimental study on IA has been recently presented in [4], in which MIMO Orthogonal Frequency Division Multiplexing (MIMO-OFDM) 3-user interference channels are measured in indoor and in outdoor scenarios. Using the measured channels, IA techniques were evaluated in an off-line fashion. This work validates the feasibility of IA techniques and also evaluates the performance degradation under spatially correlated channels. However, notice that in [4] no aligned streams are actually transmitted over the wireless channel and, thus, many practical issues such as synchronization or hardware impairments are not taken into account.

In a recent work [5] we have studied the feasibility of IA in indoor channels, identifying also the main practical issues that affect the IA performance. As pointed out in previous theoretical works [6], we have found that imperfect CSI is a key limiting factor. In this work, we continue the analysis of the IA indoor measurements presented in [5], by evaluating the impact of imperfect CSI on the performance of IA in terms of sum-rate. We have restricted the study to the 3-user interference wireless channel, where each user sends one stream and it is equipped with two antennas at both sides of the link. For this scenario, which is typically denoted as $(2 \times 2, 1)^3$, closed-form IA solutions exist that can be found solving an eigenvalue problem.

2. INTERFERENCE ALIGNMENT FOR THE 2×2 MIMO 3-USER CHANNEL

Let us consider a 3-user interference channel comprised of three transmitter-receiver pairs (links) that interfere with each other as shown in Fig. 1. The discrete-time signal at receiver i is the superposition of the signals transmitted by the three users, weighted by their respective channel gains

and affected by noise, i.e., for a given time instant:

$$\mathbf{y}_i = \mathbf{H}_{ii}\mathbf{x}_i + \sum_{j \neq i} \mathbf{H}_{ij}\mathbf{x}_j + \mathbf{n}_i \quad (1)$$

where $\mathbf{x}_i \in \mathbb{C}^{2 \times 1}$ is the signal transmitted by the i -th user, \mathbf{H}_{ij} is the 2×2 MIMO channel (assumed narrowband and time invariant) from transmitter j to receiver i , and $\mathbf{n}_i \in \mathbb{C}^{2 \times 1}$ is the additive noise at receiver i .

Spatial domain IA is achieved if we are able to design a set of beamforming vectors (precoders) $\{\mathbf{v}_i \in \mathbb{C}^{2 \times 1}\}$ and interference-suppression vectors (decoders) $\{\mathbf{u}_i \in \mathbb{C}^{2 \times 1}\}$ such that, for $i = 1, 2, 3$,

$$\begin{cases} \mathbf{u}_i^H \mathbf{H}_{ij} \mathbf{v}_j = 0, & \forall j \neq i \\ \mathbf{u}_i^H \mathbf{H}_{ii} \mathbf{v}_i \neq 0. \end{cases} \quad (2)$$

There exists a three-step analytical procedure to obtain precoders and decoders for the $(2 \times 2, 1)^3$ case [2]:

1. The precoder for user 1, \mathbf{v}_1 , is any eigenvector of the following 2×2 matrix, not necessarily the main eigenvector:

$$\mathbf{E} = (\mathbf{H}_{31})^{-1} \mathbf{H}_{32} (\mathbf{H}_{12})^{-1} \mathbf{H}_{13} (\mathbf{H}_{23})^{-1} \mathbf{H}_{21}. \quad (3)$$

2. The precoders for users 2 and 3, \mathbf{v}_2 and \mathbf{v}_3 , are respectively obtained as

$$\mathbf{v}_2 = (\mathbf{H}_{32})^{-1} \mathbf{H}_{31} \mathbf{v}_1, \text{ and} \quad (4)$$

$$\mathbf{v}_3 = (\mathbf{H}_{23})^{-1} \mathbf{H}_{21} \mathbf{v}_1. \quad (5)$$

- Since \mathbf{E} is a full-rank 2×2 matrix, there are two ways of choosing the precoder for the first user. Each one of these possibilities yields a distinct IA solution. An interesting fact of the 3-user interference channel is that it induces a permutation structure which makes that starting the procedure described above with a different user yields exactly the same set of IA solutions. In summary, there are only two different IA solutions for this scenario.
3. Finally, the interference-suppression filters (decoders) are designed to lie in the orthogonal subspace of the received interference signal.

When IA precoders and decoders are applied at both sides of the link, the signal received by the i -th user is

$$\begin{aligned} \mathbf{r}_i &= \mathbf{u}_i^H \mathbf{H}_{ii} \mathbf{v}_i s_i + \sum_{j \neq i} \mathbf{u}_i^H \mathbf{H}_{ij} \mathbf{v}_j s_j + \mathbf{u}_i^H \mathbf{n}_i \\ &= \mathbf{u}_i^H \mathbf{H}_{ii} \mathbf{v}_i s_i + \mathbf{u}_i^H \mathbf{n}_i, \end{aligned}$$

where s_i is the transmitted signal vector of the i -th user. Notice that the signal from the i -th transmitter to the i -th receiver travels through an equivalent Single-Input Single-Output (SISO) channel, $\mathbf{u}_i^H \mathbf{H}_{ii} \mathbf{v}_i$, and the interference terms are perfectly suppressed by projecting the received signal onto the subspace whose basis is \mathbf{u}_i .

3. MEASUREMENT METHODOLOGY

For experimentally evaluating IA techniques on realistic scenarios, we have built a multiuser testbed by integrating two existing multiuser MIMO testbeds developed at the Universities of A Coruña (UDC) and Cantabria (UC), respectively [7]. Notice that our approach permits that most processing blocks (frame detection, synchronization, ...) are

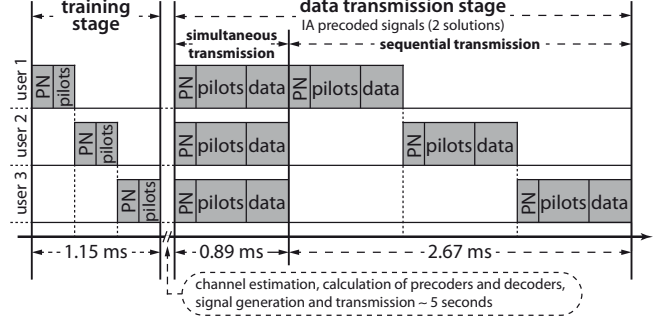

Figure 2: Frame structure designed for the assessment of IA performance. Note that the “data transmission stage” is transmitted twice (once per each of the two IA solutions).

carried out offline. As a result, development time and costs are reduced. More details about the testbed hardware can be found in [5].

Figure 2 shows the structure of the frame designed to evaluate IA schemes with three users, detailing exactly when a given user is transmitting, while assuming that all receivers are continuously acquiring. Such a frame structure consists of the following stages:

- **Training stage:** all users sequentially transmit a frame consisting of a Pseudo-Noise (PN) sequence for synchronization and pilot symbols for channel estimation. During this transmission stage, all three receivers are acquiring. Once all training signals have been acquired, the following steps are carried out:
 1. All nine pairwise Multiple-Input Multiple-Output (MIMO) channel matrices are estimated. We denote the nine MIMO channel estimates as $\hat{\mathbf{H}}_{ij} \forall i, j \in \{1, 2, 3\}$.
 2. The set of IA precoders and decoders for the two IA solutions is calculated (i.e. $\{\hat{\mathbf{v}}_i\}$ and $\{\hat{\mathbf{u}}_i\}$) and signal generation and uploading to the transmit nodes takes place. Such operations take around five seconds to be completed.
- **Data transmission stage:** signals are beamformed using the previously calculated set of IA precoders. Given that there are two IA solutions for the $(2 \times 2, 1)^3$ network, the data transmission stage is carried out twice, once for each IA solution. The data transmission stage comprises two phases:
 1. **Simultaneous transmission:** all users transmit simultaneously to recreate an interference channel.
 2. **Sequential transmission:** exactly the same frames transmitted in the previous stage are now sent in a sequential way, hence allowing us to estimate the actual interference channels seen by any receiver during the simultaneous transmission. Using the IA precoders and decoders is obviously not optimal during the sequential transmission. Our reason for using them is that they allow us to estimate the actual pairwise SISO interference channels and to evaluate the quality of the alignment by comparing the actual performance of IA (simultaneous transmission) to that obtained in absence of interference (sequential transmission).

In a recent work [5] we have evaluated the sum-rate perfor-

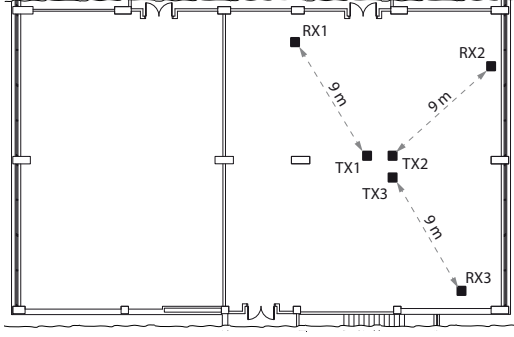

Figure 3: Measurement scenario in a lecture room at the Faculty of Informatics, University of A Coruña.

mance of IA using the described frame structure, allowing us to identify the main practical issues that affect the IA performance. Specifically, our study revealed that channel estimation errors can be an important limiting factor because of the residual interference they produce.

The sequential transmission phase allows us to estimate—in absence of interference—all pairwise channels. These estimates can then be compared to those obtained during the training stage. All receivers are able to decode the signal from the rest of the transmitters, hence each receiver is able to estimate three different Single-Input Multiple-Output (SIMO) channels. We will denote these SIMO channel estimates as $\hat{\mathbf{h}}_{ij}$. If no channel estimation errors or channel variations were present, these estimates should exactly match the presumed SIMO channels obtained in the training stage: $\hat{\mathbf{H}}_{ij}\hat{\mathbf{v}}_j$. Furthermore, by applying the IA decoders to the received signal during the sequential transmission phase, it is also possible to estimate the equivalent SISO channels for each link. These estimated SISO channels are denoted as \hat{h}_{ij} and, in an ideal situation, they should match the presumed channels obtained from the parameters estimated in the training stage: $\hat{\mathbf{u}}_i^H \hat{\mathbf{H}}_{ij} \hat{\mathbf{v}}_j$.

Finally, the whole measurement campaign involved a large number of executions of the previously described procedure over different wireless channels. With the aim of obtaining statistically-rich channel realizations, around 1000 measurements have been carried out, employing different antenna configurations, within the 5 GHz Industrial, Scientific and Medical (ISM) band.

4. MEASUREMENT SET-UP

Figure 3 presents a sketch of a lecture room at the Faculty of Informatics of the UDC. This scenario is utilized to emulate the interference network scheme shown in Fig. 1. Three transmit nodes are configured with the same transmit power value and they are located at the center of the room, each one separated nine meters away from the corresponding receive node. During the measurements, the access to the room was controlled to guarantee no moving objects in the surroundings. Additionally, we also checked that the 5 GHz ISM band was not occupied by any other device. Finally, all nodes were equipped with monopole antennas at both sides of each link, while antenna spacing is set to approximately seven centimeters.

Figure 4 (a) shows a block diagram of the signal processing chain at the transmit side. The dashed lines indicate that

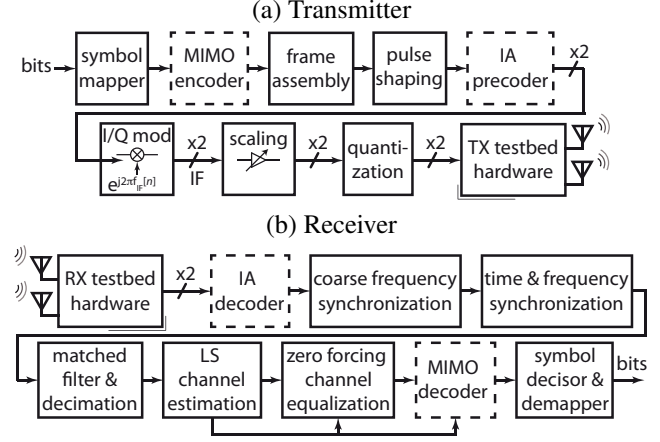

Figure 4: Signal processing chain at the transmit side (top figure) and at the receive side (bottom figure).

the corresponding blocks are only utilized at a given transmit stage. On the one hand, the MIMO encoder is only employed during the training stage to generate signals to be transmitted by each node. On the other hand, the so-called IA precoder is only used during the data transmission stage. The signal processing chain at the transmit side comprises the following steps:

- Source bits are mapped to a 4-QAM constellation up to 500 data symbols, while pilots (256 symbols) employ a BPSK mapping.
- During the training stage, the resulting symbols are encoded to produce a single symbol stream per antenna.
- A PN sequence (127 BPSK symbols) is added as a preamble for synchronization in the frame assembly block.
- Signals are up-sampled resulting in 40 samples per symbol. Pulse-shaping is done using a squared root-raised cosine filter with 40% roll-off, leading to a signal bandwidth of 1.4 MHz (Digital-to-Analog Converters (DACs) sampling frequency is set to 40 MHz).
- During the data transmission stage, the obtained real-valued, up-sampled transmit signals are beamformed using the IA precoders.
- Next, the signals are scaled, quantized according to the 16 bits DACs resolution, and then stored in the buffers available at the transmit nodes of the testbed.
- Once all signals are ready to be transmitted, all transmit nodes are triggered, and the transmission starts simultaneously.

Figure 4 (b) shows the corresponding signal processing operations at the receive side. The same considerations pointed out for the MIMO encoder and the IA precoder in Fig. 4 (a) are valid for the MIMO decoder and the IA decoder in Fig. 4 (b). Once the receivers have been triggered, they capture the signals that are being transmitted and they generate the corresponding baseband signals, which are stored in buffers at the receive nodes. Afterwards, the following steps are carried out:

- During the data transmission stage, the first signal processing operation is the interference suppression by means of the IA decoders.
- Next, coarse frequency synchronization takes place, fol-

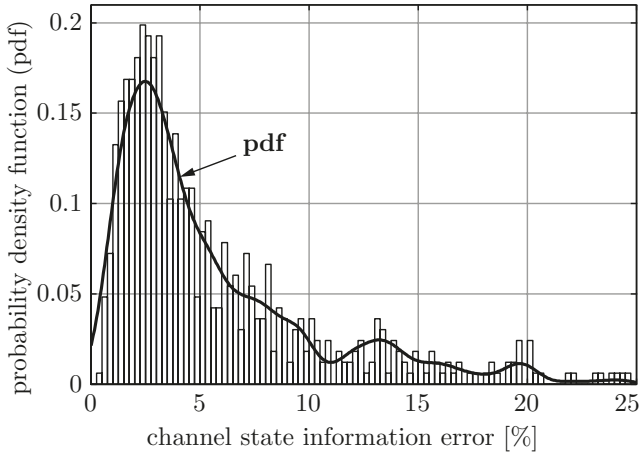

Figure 5: Histogram and estimated pdf of the mean of the nine CSI errors defined in Eq. (9) for all measurements.

lowed by time and fine frequency synchronization.

- The resulting signals are filtered and decimated. Instantaneous receive power is estimated during transmission periods whereas the noise variance estimate $\hat{\sigma}_i^2$ is obtained during the non-transmission periods. Such values are needed for estimating the instantaneous Signal-to-Noise Ratio (SNR) value at each receiver.
- Making use of a conventional Least Squares (LS) approach, the channel is estimated utilizing the 256 pilot symbols included in the transmit frame.
- During the training stage, the complex-valued symbols are processed by the MIMO decoder.
- Finally, a symbol-by-symbol decisor followed by a demapper outputs the estimated bits.

5. DISCUSSION OF THE RESULTS

The results shown in this section require several previous definitions. First, we define a total of nine CSI errors, E_{ij} , as the relative difference between the SIMO channel estimates during the training and the data transmission stages:

$$E_{ij} = \frac{\|\hat{\mathbf{H}}_{ij}\hat{\mathbf{v}}_j - e^{j\hat{\theta}_{ij}}\hat{\mathbf{h}}_{ij}\|^2}{\|\hat{\mathbf{H}}_{ij}\hat{\mathbf{v}}_j\|^2} \quad (6)$$

where the term $e^{j\hat{\theta}_{ij}}$ is used to correct the estimated phase difference, $\hat{\theta}_{ij}$, existing between both stages. This phase difference is due to the lack of synchronization between the transmitter and the receiver, but it is not a problem for the alignment.

In addition, we can also estimate the achievable sum-rates for both simultaneous and sequential IA transmissions. On the one hand, the sum-rate for the simultaneous IA transmission is estimated by taking into account the residual interference from the rest of the users as

$$\text{SR}_{\text{IA}} = \sum_{i=1}^3 \log_2 \left(1 + \frac{|\hat{h}_{ii}|^2}{\hat{\sigma}_i^2 + \sum_{j=1, j \neq i}^3 \|\hat{\mathbf{u}}_i^H \hat{\mathbf{h}}_{ij}\|^2} \right), \quad (7)$$

where the equivalent SISO channel for the interfering links is estimated as $\hat{\mathbf{u}}_i^H \hat{\mathbf{h}}_{ij}$. On the other hand, the sum-

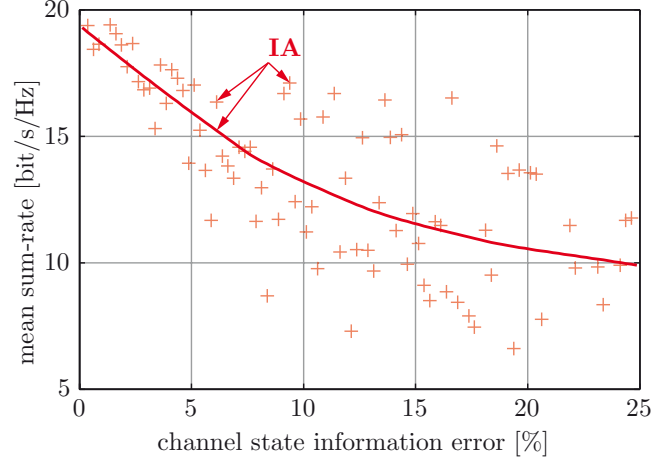

Figure 6: Impact of mean CSI error on the mean sum-rate.

rate corresponding to the sequential IA transmission — denoted as “perfect IA” because it takes place in absence of interference— is estimated as

$$\text{SR}_{\text{perfect IA}} = \sum_{i=1}^3 \log_2 \left(1 + \frac{|\hat{h}_{ii}|^2}{\hat{\sigma}_i^2} \right). \quad (8)$$

5.1 Sum-Rate Degradation Due to CSI Errors

As it can be directly observed from Eqs. (3) to (5), the design of IA precoders and decoders has a heavy reliance on network-wide CSI. In practice, this causes two different problems. The most obvious one is that the IA solution is highly sensitive to channel estimation errors. The second problem is that the IA precoders and decoders must be transferred from a central site, where the solution is obtained, to all nodes participating in the alignment. This fact introduces a delay between the channel estimation stage and the actual IA transmission stage. During this time the channel may vary, especially when there are moving scatterers in the surroundings.

Both aforementioned problems affect similarly the IA performance and are difficult to separate in practice. For that reason, we quantify the joint effect by means of the average CSI error, E , which is obtained as the mean of the nine pairwise E_{ij} errors defined in Eq. (6):

$$E = \frac{1}{9} \sum_{i=1}^3 \sum_{j=1}^3 E_{ij}. \quad (9)$$

The probability density function (pdf) of E (with E shown as a percentage), and its impact on the mean sum-rate are shown in Fig. 5 and Fig. 6, respectively. In the latter, it can be seen how the mean sum-rate performance degrades rapidly with channel estimation errors. Figure 7 compares the sum-rate achieved by IA assuming perfect interference suppression — evaluated using the sequential transmission (see Fig. 2)— and the actual sum-rate achieved by IA —obtained utilizing the simultaneous transmission (see Fig. 2)—. Each point in the figure corresponds to a particular channel realization. More specifically, the points labeled as “IA” have been calculated using Eq. (7) and represent the achieved sum-rate taking into account the residual interference due to CSI errors. On the other hand, the points labeled as “perfect IA”

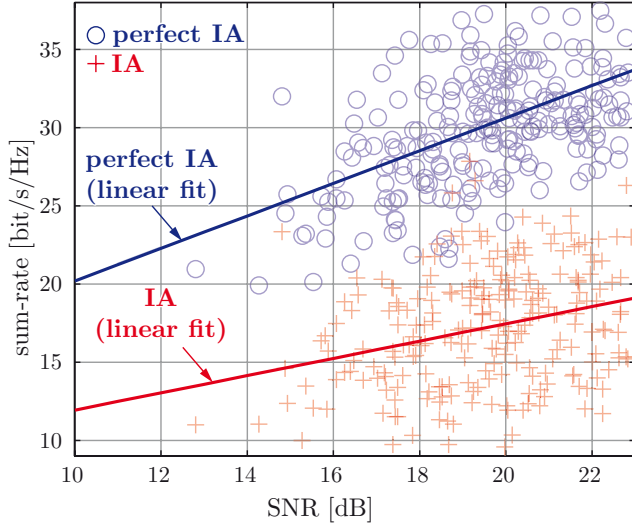

Figure 7: Comparison of the sum-rate achieved by the IA technique assuming perfect alignment (perfect IA) and the actual measurements with CSI errors.

have been obtained using Eq. (8) and represent the sum-rate in the absence of interference. Further, a linear fit of the points has been obtained in order to estimate the degrees of freedom achieved in the transmission [2]. It reveals that the residual interference causes a mean sum-rate degradation of 13 bit/s/Hz, as well as a significant loss in terms of degrees of freedom. In fact, IA has achieved 1.7 degrees of freedom while the theoretical value (achieved by perfect IA) is 3.

5.2 Choosing the Maximum Sum-Rate IA Solution

As mentioned in Section 2, two different IA solutions exist for the 3-user interference channel. Furthermore, for a given channel, these solutions might have very different performance values in terms of sum-rate, robustness against channel estimation errors, etc. For the considered $(2 \times 2, 1)^3$ network, we can perform an exhaustive search in order to find the best solution according to a certain performance metric. In this section we try to improve the performance by selecting the best IA solution in terms of sum-rate. Specifically, we choose the solution that maximizes the sum-rate given by

$$SR = \sum_{i=1}^3 \log_2 \left(1 + \frac{|\hat{\mathbf{u}}_i^H \hat{\mathbf{H}}_{ii} \hat{\mathbf{v}}_i|^2}{\hat{\sigma}_i^2} \right), \quad (10)$$

which is evaluated using the MIMO channel estimated in the training stage. Figure 8 plots the sum-rate achieved by the aforementioned strategy (labeled as “IA maximum sum-rate”) as well as the sum-rate of a randomly selected solution (labeled as “IA random”). The curve labeled as “IA random” in Fig. 8 is the same as that labeled as “IA (linear fit)” in Fig. 7. Figure 8 also shows that the maximum sum-rate solution provides a mean sum-rate improvement of 1.8 bit/s/Hz over the random solution while there is no change with respect to the achieved degrees of freedom.

6. CONCLUSION

In this paper we have studied the impact of CSI errors on the sum-rate performance of IA. Our results suggest that future

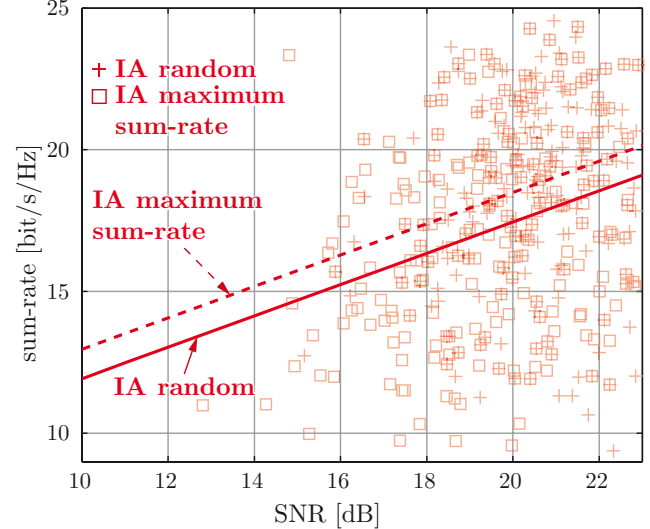

Figure 8: Improvement provided by the maximum sum-rate solution with respect to random IA solution selection.

theoretical work must be focused on designing robust and/or dynamic interference alignment algorithms to deal with imperfect channel state information [8] and exploiting the characteristics of different alignment solutions for each scenario.

Acknowledgments

This work has been funded by Xunta de Galicia, Ministerio de Ciencia e Innovación of Spain, and FEDER funds of the European Union under grants with numbers 10TIC003CT, 09TIC008105PR, TEC2010-19545-C04-01, TEC2010-19545-C04-03, AP2009-1105, AP2006-2965, and CSD2008-00010.

REFERENCES

- [1] M. Maddah-Ali, A. Motahari, and A. Khandani, “Signaling over MIMO multi-base systems: Combination of multi-access and broadcast schemes,” in *IEEE International Symposium on Information Theory*, pp. 2104–2108, July 2006, doi: 10.1109/ISIT.2006.261922.
- [2] V. Cadambe and S. Jafar, “Interference alignment and degrees of freedom of the K-user interference channel,” *IEEE Transactions on Information Theory*, vol. 54, no. 8, pp. 3425–3441, Aug. 2008, doi: 10.1109/TIT.2008.926344.
- [3] S. Gollakota, S. D. Perli, and D. Katabi, “Interference alignment and cancellation,” *SIGCOMM Comput. Commun. Rev.*, vol. 39, pp. 159–170, Aug. 2009, doi: 10.1145/1594977.1592588.
- [4] O. El Ayach, S. Peters, and R. W. Heath, “The feasibility of interference alignment over measured MIMO-OFDM channels,” *IEEE Transactions on Vehicular Technology*, vol. 59, no. 9, pp. 4309–4321, 2010, doi: 10.1109/TVT.2010.2082005.
- [5] Ó. González *et al.*, “Experimental validation of interference alignment techniques using a multiuser MIMO testbed,” in *International ITG Workshop on Smart Antennas (WSA)*, Feb. 2011, doi: 10.1109/WSA.2011.5741921.
- [6] R. Tresh and M. Guillaud, “Cellular interference alignment with imperfect channel knowledge,” in *Proc. IEEE International Conference on Communications*, pp. 971–975, 2009, doi: 10.1109/ICC.2008.190.
- [7] D. Ramírez *et al.*, “A comparative study of STBC transmissions at 2.4 GHz over indoor channels using a 2x2 MIMO testbed,” *Wireless Communications and Mobile Computing*, vol. 8, no. 9, pp. 1149–1164, Nov. 2008, doi: 10.1002/wcm.558.
- [8] E. Chiu *et al.*, “Robust transceiver design for K-pairs quasi-static MIMO interference channels via semi-definite relaxation,” *IEEE Transactions on Wireless Communications*, vol. 9, no. 12, pp. 3762–3769, 2010, doi: 10.1109/TWC.2010.101310.091849.